

The logo for the Australian Communications Industry Forum (ACIF) features the letters 'ACIF' in a bold, dark blue, sans-serif font. The letters are partially enclosed by a circular graphic composed of several overlapping, light blue, curved lines that create a sense of motion or a stylized globe.

ACIF

A large, decorative graphic in a light blue color dominates the background. It consists of several overlapping, curved lines that spiral inward from the top left towards the center, creating a dynamic, swirling effect.

AUSTRALIAN COMMUNICATIONS INDUSTRY FORUM

INDUSTRY CODE

END-TO-END NETWORK PERFORMANCE

ACIF C519 OCTOBER 1998

Industry Code - End-To-End Network Performance

This Code was issued in draft form for comment as DR ACIF C519

First published as ACIF C519:1998

ISBN: 1 74000 013 7

© Copyright Australian Communications Industry Forum,
PO Box 444 Milsons Point NSW 1565

Disclaimers

- 1 Notwithstanding anything contained in this Code:
 - (a) ACIF disclaims responsibility (including where ACIF or any of its officers, employees, agents or contractors has been negligent) for any direct or indirect loss, damage, claim, or liability any person may incur as a result of any:
 - (i) reliance on or compliance with this Code;
 - (ii) inaccuracy or inappropriateness of this Code; or
 - (iii) inconsistency of this Code with any law; and
 - (b) ACIF disclaims responsibility (including where ACIF or any of its officers, employees, agents or contractors has been negligent) for ensuring compliance by any person with this Code.
- 2 The above disclaimers will not apply to the extent they are inconsistent with any relevant legislation.

Copyright

This document is copyright. You may reproduce it only as necessary for the purposes of you or your organisation considering or pursuing compliance with this Code. You must not alter or amend this Code.

TABLE OF CONTENTS

1	FOREWORD	1
2	PARTICIPANTS	3
3	INTRODUCTION	5
3.1	Objectives	5
	Protect Interests of End Users	5
	Assist Industry Interworking	5
3.2	Legislative Framework	6
3.3	Scope and Application	6
3.4	Relationship to ACIF's Code Administration and Compliance Scheme	7
4	REFERENCED STANDARDS AND PUBLICATIONS	9
5	ABBREVIATIONS AND DEFINITIONS	11
5.1	Abbreviations	11
5.2	Definitions	12
6	CODE RULES	15
6.1	Network Performance Parameters and Compliance	15
6.2	Network Performance Requirements	16
	End-to-End Connection Setup Failure	17
	Post Dialling Delay	17
	Transmission Loss and Nominal Relative Network Levels	18
	Loudness Loss	19
	Circuit Noise	20
	Delay and Echo	20
	Network Synchronisation and Slip	21
7	COMPLIANCE PROCESS	23
7.1	Routine Compliance Verification	23
	Operational Measurement	23
	Attestation of Performance	24
	ACIF Diagnosis and Rectification	24
7.2	Identification of Performance Anomalies	24
	Industry Network Performance Complaints	24
	Trend or Pattern of Consumer Network Performance Complaint	24
7.3	Compliance Verification by Exception Testing	26
	Directed Operational Measurement	26
	Independent Network Design Verification	26
	ACIF Diagnosis and Rectification	26

8 COMPLIANCE TEST METHODS	27
8.1 Compliance Test Method 1 - Routine End-to-End Operational Measurement	27
Distribution of Measurement Devices	27
Distribution of Test Calls	27
Measurement Periods	27
Number of Test Calls Required	27
Criteria for Achievement of Objectives	27
Reporting Period	28
8.2 Compliance Test Method 2 - Routine Compliance by Self-Attestation	28
8.3 Compliance Test Method 3 - Operational Measurement by Exception	28
8.4 Compliance Test Method 4 - Independent Network Design Verification	28
9 CODE ADMINISTRATION	29
9.1 Registering Participation	29
9.2 Publicity	29
Publicity of Compliance Test Method 1 Outcome	30
Publicity of Compliance Test Method 2 Outcome	30
Publicity of Compliance Test Method 3 Outcome	30
Publicity of Compliance Test Method 4 Outcome	30
9.3 Financial and Sanction Administration	30
9.4 ACIF Administration of Compliance Testing	30
9.5 Confidentiality	31
9.6 Code Review	32
9.7 Code Amendment	32
10 CODE COMPLAINT MANAGEMENT PROCESS AND SANCTIONS	33

1. Foreword

- 1.1 This Industry Code for end-to-end network performance, hereinafter referred to as the “Code”, is intended to address the industry approach to self-regulation of end-to-end network performance. The Code is a companion to the Australian Communications Industry Forum (ACIF) Specification G502, Australian Network Performance Plan (ANPP) Version 1.0, 1998, and is intended to apply to fixed and mobile networks in Australia for voice telephony. If there is any inconsistency as between this Code and the ANPP, this Code shall prevail to the extent of such inconsistency.
- 1.2 This Code has been developed under the auspices of ACIF. Since 1st July 1997, the Australian telecommunications industry has been deregulated. This Code is a mechanism to ensure voice telephony delivered over fixed and mobile networks achieves an acceptable quality of overall end-to-end network performance. This Code together with its companion, the ANPP, when registered with the Australian Communications Authority (ACA) are intended to replace ACA Technical Standard TS 027.
- 1.3 This Code establishes an industry framework for Carriers and Carriage Service Providers (CSPs) to demonstrate compliance of their overall network performance to a set of parameter objectives by:
 - (a) operational measurements for connectivity parameters and
 - (b) verification of network design for transmission parameters.
- 1.4 A list of complying Carriers and CSPs will be published by ACIF. Non-compliance with this Code can result in the enforcement of sanctions.
- 1.5 This Code and the ANPP is subject to regular review to cater for new and emerging technologies and techniques for voice telephony.
- 1.6 Under ACIF Code signatory arrangements, signatories to this code (Code Participants) are subject to ACIF’s Code Administration and Compliance Scheme (October 1998) (*the Scheme*). Accordingly all signatories (Code Participants) who are bound by this Code are also bound by the Scheme.

INDUSTRY CODE

2 Participants

The Network Performance Working Committee that developed this Industry Code consisted of the following organisations and representatives:

Representative	Organisation
Yasmin Dugan (Chairperson)	Telstra Corporation
Alex Quan (Editor)	Telstra Corporation
Glenn Dewhurst	AAPT
Scott Nelson	Alcatel Australia
Ken Bell	Australian Communications Authority (ACA)
John Pack	Australian Telecommunications User Group (ATUG)
Helen Campbell	Consumers' Telecommunications Network (CTN)
Andrew Pollard	Ericsson Australia
Mike Elsegood	Optus Communications
Allan Sangster	Sangster and Spitzer
James Park	Siemens Australia
Guillermo Bolger	Teleresources
Tony Stewart	Telstra Corporation
Davorka Karacic	Vodafone Network
Michael Woodman	Vodafone Network

Chiang Lim and James Duck of ACIF supplied project management support.

INDUSTRY CODE

3 INTRODUCTION

3.1 Objectives

- 3.1.1 This Code addresses the industry approach to self-regulation of end-to-end network performance. The Code however, is not the only mechanism by which industry self-regulation will be achieved. Industry agreed design guidelines such as the Australian Communications Industry Forum (ACIF) Specification G502, Australian Network Performance Plan (ANPP) Version 1.0, 1998, and individual interconnection agreements between Carriers and Carriage Service Providers (CSPs) also have their part to play in the industry approach to self-regulation. The Code complements these other mechanisms and provides visible and specific criteria through which the effectiveness of industry response to self-regulation of end-to-end network performance can be monitored. The Code is a companion to the ANPP and establishes an industry framework for network operators to demonstrate compliance by:
- (a) operational measurements using a Test Call System for connectivity parameters; and
 - (b) independent verification of network design for transmission parameters.
- 3.1.2 If there is any inconsistency as between this Code and the ANPP, this Code shall prevail to the extent of such inconsistency.
- 3.1.3 The two prime aims of the Code are given in Clauses 3.1.4 to 3.1.6.

Protect Interests of End Users

- 3.1.4 This Code specifies the requirements for checking the overall end-to-end network performance of the multi-service deliverer, multi-network environment in Australia. It will assure end users, Regulators and Government that Carriers' switched networks, CSPs' switched networks and Private Networks when connected to public networks, provide an acceptable level of overall end-to-end network quality for voice telephony and basic voice-band data modulation for teletypewriter (TTY) or equivalent equipment to be provided to end users.

Assist Industry Interworking

- 3.1.5 This Code assists industry interworking through reference to relevant industry design specifications and standards. It will also assure access providers and access seekers that other network components used in establishing connections will enable an acceptable level of overall end-to-end network quality for voice telephony and basic voice-band data modulation for TTY or equivalent equipment to be provided to end users.
- 3.1.6 The objectives of the Code will be achieved through:
- (a) responding to changes in customer needs, technology and market requirements;
 - (b) setting of operational limits for key parameters;
 - (c) verification procedures - such as design documentation, testing or monitoring;
 - (d) responding to complaint patterns and trends;
 - (e) rules for corrective action;

- (f) sanctions for non-compliance; and
- (g) Code administration, including compliance reporting, Code awareness and the ACIF Code compliance regime.

3.2 Legislative Framework

- 3.2.1 Part 6 of the *Telecommunications Act, 1997* identifies the role of Industry Codes, developed by the industry, to apply to participants in the industry in relation to their telecommunications activities. The Act defines requirements for the development of Codes and their registration by the Australian Communications Authority (ACA).
- 3.2.2 One of the matters identified as one which may be subject to an Industry Code identified in section 113 (3) (m) of the *Telecommunications Act, 1997* is “*the quality of standard telephone services*”. Section 115 (2) allows a Code dealing with the quality of standard telephone services to have an effect on a telecommunications network or a facility, customer equipment or customer cabling design features and performance requirements.
- 3.2.3 The *Telecommunications (Transitional Provisions and Consequential Amendments) Act 1997*, section 52, contains provisions for ACA Technical Standard TS 027, End-to-End Network Performance, determined under the Telecommunications Act 1991, to continue as an Industry Standard under the Telecommunications Act 1997.
- 3.2.4 However, the standard may be revoked, in accordance with section 131 of the *Telecommunications Act 1997* if a Code intended to replace the standard is registered with the ACA.

3.3 Scope and Application

- 3.3.1 This Code is intended to apply to fixed and mobile networks operated by Carriers, CSPs and private network operators supplying carriage services for the purpose of voice telephony, consistent with the definition of standard telephone service in section 17 of the *Telecommunications Act 1997*. Voice-band data modems at 2400 bit/s are expected to support forms of communication equivalent to voice telephony where voice telephony is not practical for a particular end user. The fixed networks for voice telephony complying with this Code shall also support voice-band data transmission at speeds of at least 2400 bit/s using a TTY or a modern voice-band data modem such as one conforming to ITU-T Recommendation V.34. Public Digital Mobile Networks support direct data transmission and therefore are not required to support voice-band data modems.
- 3.3.2 This Code defines the overall end-to-end network performance for the following call cases:
 - (a) Fixed network ↔ fixed network.
 - (b) Fixed network ↔ Public Digital Mobile Network.
 - (c) Public Digital Mobile Network ↔ Public Digital Mobile Network.

- 3.3.3 This Code applies to voice telephony connections across all networks in Australia as illustrated in the reference telecommunications network in Figure 3.1. This Code currently does not apply to emerging voice telephony services including internet telephony which use packet, frame or cell-based voice telephony connections. However, these emerging services may use the performance levels in this Code as indicative target objectives. Performance requirements in this Code and the ANPP will be reviewed to cater for these services and are for further study.
- 3.3.4 Network performance of services that are not part of a standard telephone service is outside the scope of this Code.

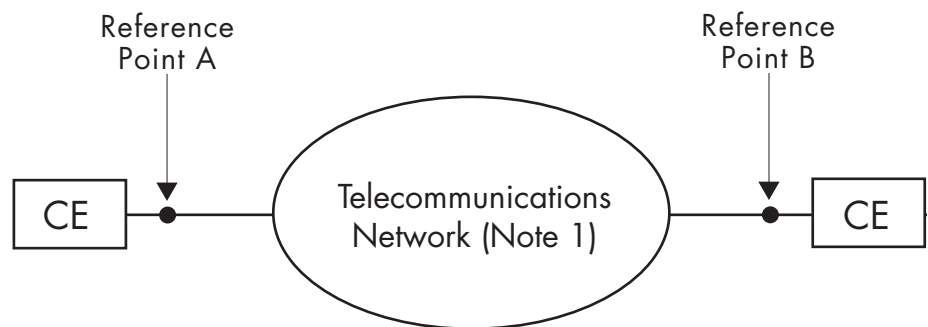

Note 1: The “telecommunications network” include such carrier networks and private networks making up the connection between two CEs.

CE: Customer Equipment (eg. telephone or teletypewriter (TTY)).

FIGURE 3.1

Reference Telecommunications Network

- 3.3.5 In regard to Public Digital Mobile Networks, this Code only applies to GSM networks using Full Rate speech transcoding described in ETSI ETS 300 96 (GSM 06.01). GSM networks using other speech transcoding techniques such as Half Rate and Enhanced Full Rate require further study.
- 3.3.6 This Code does not apply to or define the performance of an individual telecommunications service or call. The Code also does not apply to calls made to non-geographic service number Fixed Network Terminations (FNTs).
- 3.3.7 This Code does not apply to private network calls that do not connect to public networks, or to user controlled facilities (for example, customer queuing systems for outgoing calls).

3.4 Relationship to ACIF’s Code Administration and Compliance Scheme

- 3.4.1 Under the ACIF Code signatory arrangements, signatories to this code (Code Participants) are subject to ACIF’s Code Administration and Compliance Scheme (October 1998) (*the Scheme*). Accordingly all signatories (Code Participants) who are bound by this Code are also bound by the Scheme.

INDUSTRY CODE

4 REFERENCED STANDARDS AND PUBLICATIONS

This Code refers to the standards and publications in Tables 4.1 to 4.4.

Publication	Title
TS 004	Voice Frequency Performance Requirements for Customer Equipment (1997).
TS 016	General Requirements for Customer Equipment Connected to Hierarchical Digital Interfaces (1997).
TS 027	End-to-End Network Performance (1996).

TABLE 4.1
ACA Technical Standards

Publication	Title
G.100	Definitions used in Recommendations on general characteristics of international telephone connections and circuits (03/93).
G.822	Controlled slip rate objectives on an international digital connection [Blue Book Fascicle III.5].
P.79	Calculation of loudness ratings for telephone sets (03/93).
V.34	A modem operating at data signalling rates of up to 33 600 bit/s for use on the general switched telephone network and on leased point-to-point 2-wire telephone-type circuits (10/96).
Blue Book Fascicle I.3	Terms and definitions.

TABLE 4.2
ITU-T Standards

Publication	Title
ETS 300 96	Digital cellular telecommunications system; Full rate speech; Processing functions (GSM 06.01, May 1997).

TABLE 4.3
ETSI Standards

Description
1 Australia - <i>Telecommunications Act 1991</i> (No.98, 1991)
2 Australia - <i>Telecommunications Act 1997</i> (No.47, 1997)
3 Australia - <i>Telecommunications (Transitional Provisions and Consequential Amendments) Act 1997</i> (No.59, 1997)
4 Austel TS 012 - "General Requirements for the Connection of Private Networks to the Public Switched Network" (1992)
5 ACIF Specification G502:1998 - "Australian Network Performance Plan" (Version 1.0, 1998)
6 ACIF G514:1998 - "Code Administration and Compliance Scheme" (October 1998)

TABLE 4.4
Publications

INDUSTRY CODE

5 ABBREVIATIONS AND DEFINITIONS

5.1 Abbreviations

ACA	Australian Communications Authority
ACIF	Australian Communications Industry Forum
AN	Access Network
ANPP	Australian Network Performance Plan
CE	Customer Equipment
CSP	Carriage Service Provider
ETSI	European Telecommunications Standards Institute
FNT	Fixed Network Termination
GEO	Geostationary Earth Orbit (Satellite)
GSM	Global System for Mobile Communications
HFC	Hybrid Fibre-Coaxial
IEN	Inter-Exchange Network
ISC	International Switching Centre
ISDN	Integrated Services Digital Network
ITU-T	International Telecommunication Union - Telecommunication-Standardization Sector
MAI	Mobile Air Interface
OLR	Overall Loudness Rating
PCM	Pulse Code Modulation
PN	Private Network
POC	Point of Connect
POI	Point of Interconnection
PRC	Primary Reference Clock
TIO	Telecommunications Industry Ombudsman
TrN	Transit Network
TS	Technical Standard
TTY	Teletypewriter
VF	Voice Frequency

5.2 Definitions

Access Network is the telecommunications network that a customer or end-user terminal is directly connected to in order to initiate or receive telephone calls. In the case of calls traversing more than one network, the Access Network connects the customer or end-user terminal to the nearest POI.

Code Participant means a Carrier, CSP or private network operator who is a signatory to the Code.

Confidential Information means all information (whether in tangible form or not), disclosed or otherwise provided by a Code Participant or otherwise obtained by ACIF, under or in connection with this Code and may include, but is not limited to, information concerning:

- details of customers;
- access switch technology;
- geographic coverage;
- traffic flows;
- equipment specifications;
- network plans;
- network design specifications and documentation; and
- other Carriers used and their network apportionment.

Circuit Noise is the short-term average noise power on an idle channel or connection, i.e. a channel with a termination and no signal at the transmitting end.

Delay (Mean One-way Propagation Time) (Reference: ITU-T G.100) in a connection is the mean of the propagation times in the two directions of transmission.

Echo (Reference: ITU-T G.100) is the unwanted signal delayed to such a degree that, for instance in telephony, it is perceived as distinct from the wanted signal (i.e. the signal directly transmitted).

End-to-End Connection Setup Failure is the ratio (expressed as a percentage) of the number of unsuccessful connection setup attempts to the total number of valid connection setup attempts.

Note 1: A connection setup attempt is considered valid only if a valid network address is dialled, and a start dial signal, if it is a feature of the service, is present before dialling commences.

Note 2: A connection setup failure will occur for any of the following conditions:

- No ring and no answer
- All circuits busy signal or equivalent recorded voice announcement
- Connection to the wrong number (misrouting)
- Start dial signal (e.g. dial tone) is present after dialling completed

End-to-End Network Performance is the performance across all interconnecting networks, public and private networks, from an FNT or MAI to another FNT or MAI. In the case of loudness rating, end-to-end network performance includes the performance of telephone handsets.

Fixed Network Termination (FNT) is the point where CE connects to an AN. The FNT is the boundary of a telecommunications network and is ascertained in the terms of an agreement between a customer and a Prime Service Deliverer. (As defined in the ANPP, a Prime Service Deliverer is the Service Deliverer contracted by a customer to provide a telecommunications service).

Global call is one which is not a mobile call, and where the location of the called party cannot be deduced by the caller from the number dialled. Examples of global calls include *freephone 1800 services and 13 services*.

Loudness Rating (ITU-T Blue Book Fascicle I.3 - Definitions) is a measure, expressed in decibels, for characterizing the loudness performance of complete telephone connections or of parts thereof such as sending system, line, receiving system. It is the amount of frequency-independent gain that must be inserted into a system under test so that speech sounds from the system under test and a reference system are equal in loudness.

Mobile Air Interface (MAI) is the air interface between a mobile handset and its Public Digital Mobile Network.

Nominal Relative Network Level at a point is the network level allocated to this point to give an optimum performance for the connection. This level is generally equal to the difference in transmission loss at the reference frequency between this point and a transmission reference point in a network connection which is considered average of all network connections.

Overall Loudness Rating is the loudness loss from the talker's mouth to the listener's ear via a connection.

Point of Connect (POC) is the point at which a private network connects with an Access Network.

Point of Interconnection (POI) is the point at which an Access Network connects to a Transit Network or another Access Network. Carriage Service Providers' networks interconnect with each other at Points of Interconnection.

Post Dialling Delay is the time interval between the end of user or originating customer equipment dialling and the reception of an appropriate network response. Appropriate network response includes: ring tone, busy tone, congestion tone and Recorded Voice Announcement (RVA).

Receive Loudness Rating (Reference:TS 004) is a measure of the electro-acoustic characteristic of telephone equipment with respect to the reception of speech signals from a telecommunications network.

Send Loudness Rating (Reference:TS 004) is a measure of the electro-acoustic characteristic of telephone equipment with respect to the transmission of speech signals to a telecommunications network.

Slip is defined as the repetition or deletion of a block of bits in a synchronous or plesiochronous bit stream due to a discrepancy in the read and write rates at a buffer.

Synchronisation is the process of keeping all digital elements of a network operating at the same frequency, so that no information is lost.

Transit Network (TrN) is that part of the network which connects two POIs and may connect to an Access Network or another Transit Network.

Transmission Loss (also called **Composite Loss** in ITU-T G.100) of a connection inserted between two impedances, Z_g (of the generator) and Z_l (of the load), is the expression in dB of the ratio P_g/P_l at the reference frequency f_0 where P_g is the apparent power that a generator would furnish through impedance Z_g to a load of impedance Z_g (i.e. maximum power transfer), and P_l is the apparent power that the same generator furnishes via the connection to a load of impedance Z_l .

At frequencies other than the reference frequency, the impedance terms are held to their reference frequency values, so that transmission loss indicates voltage loss only.

$$\text{Transmission loss} = 10 \log_{10} \left[\left(\frac{V_g}{2V_l(f)} \right)^2 \frac{|Z_l(f_0)|}{|Z_g(f_0)|} \right]$$

where V_g is the r.m.s. generator voltage (frequency independent), $V_l(f)$ is the r.m.s. load voltage at the *frequency of interest*, $Z_l(f_0)$ and $Z_g(f_0)$ are the impedances at a *reference frequency* f_0 , e.g. 1020 Hz.

Voice-band Data Transmission is the transmission of data within the frequency range from 300 Hz to 3400 Hz.

Voice Telephony is real time two-way communication within the frequency range 300 Hz to 3400 Hz using one or more telecommunications networks.

6 CODE RULES

The specified performance in the Code is the end-to-end network performance across all interconnecting networks, public and private, from an FNT or MAI to another FNT or MAI. The end-points are defined in the generic network reference model for voice telephony (Figure 6.1).

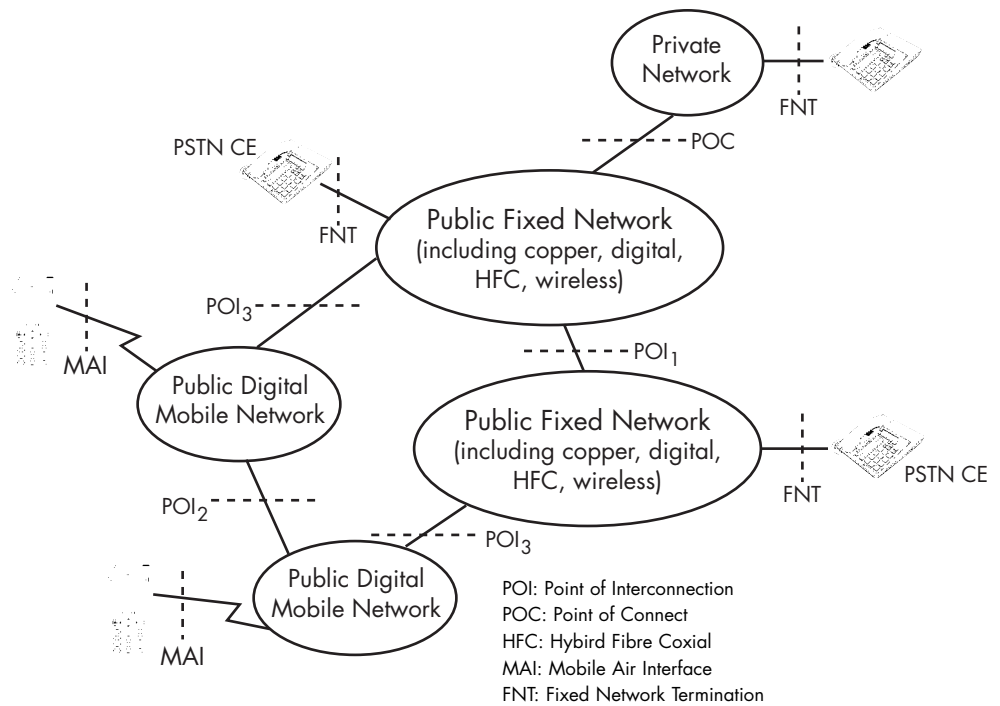

FIGURE 6.1
Generic network reference model for voice telephony

6.1 Network Performance Parameters and Compliance

- 6.1.1 This Code and the ANPP together are intended to replace ACA Technical Standard TS 027. Compliance to the network performance levels in the Code ensures interconnected networks provide an acceptable quality of end-to-end network performance. The network performance specified in the Code is for voice telephony. For support of alternative services to voice telephony, for those persons for whom voice telephony is not suitable, network performance consistent with the Code should also facilitate voice-band data transmission at speeds of at least 2400 bit/s. Code Participants may use different networking methods for voice and modem data transport that together meet the objectives of voice and data network performance quality.
- 6.1.2 The network performance parameters covered by this Code are listed in Table 6.1. These parameters are classified into two groups, connectivity network performance parameters (Connection Setup Failure and Post Dialling Delay) and transmission network performance parameters (Transmission Loss and Nominal Relative Network Levels, Loudness Loss, Circuit Noise, Delay and Echo, and Network Synchronisation and Slip). This type of parameter determines the Compliance Test Method used. Compliance to network performance for voice telephony is demonstrated through the test methods listed in Table 6.1.

- 6.1.3 Compliance Test Method 1 (Routine End-to-End Operational Measurement) of Section 8.1 shall apply to end-to-end operational measurements of the two connectivity network performance parameters. If compliance verification by exception testing is required, Compliance Test Method 3 (Operational Measurement by Exception) of Section 8.3 shall be applied.
- 6.1.4 Compliance Test Method 2 (Routine Compliance by Self-Attestation) of Section 8.2 shall apply to the transmission network performance parameters. If compliance verification by exception testing is required, Compliance Test Method 4 (Independent Network Design Verification) of Section 8.4 shall be applied.

Parameter	Compliance Test Method
Connection Setup Failure	Compliance Test Method 1 of Section 8.1 (end-to-end testing only) If required, Compliance Test 3 of Section 8.3
Post Dialling Delay	Compliance Test Method 1 of Section 8.1 (end-to-end testing only) If required, Compliance Test Method 3 of Section 8.3
Transmission Loss and Nominal Relative Network Levels (Note 1)	Compliance Test Method 2 of Section 8.2. If required, Compliance Test Method 4 of Section 8.4
Loudness Loss (Note 2)	Compliance Test Method 2 of Section 8.2. If required, Compliance Test Method 4 of Section 8.4
Circuit Noise (Note 1)	Compliance Test Method 2 of Section 8.2. If required, Compliance Test Method 4 of Section 8.4
Delay and Echo	Compliance Test Method 2 of Section 8.2. If required, Compliance Test Method 4 of Section 8.4
Network Synchronisation and Slip	Compliance Test Method 2 of Section 8.2. If required, Compliance Test Method 4 of Section 8.4

Note 1: Transmission Loss, nominal relative network levels and noise which are voice-frequency band (300 Hz to 3400 Hz) network performance parameters, are not applicable to Public Digital Mobile Networks.

Note 2: Loudness loss is not applicable to Public Digital Mobile Networks since they are fully digital from the MAI to the POI. For mobile networks, all loudness loss is incurred in the mobile handsets.

TABLE 6.1

Parameters and compliance test methods for voice telephony

- 6.1.5 Compliance to network performance for voice-band data transmission may be demonstrated by design documentation attesting capability to support at least 2400 bit/s.

6.2 Network Performance Requirements

- 6.2.1 This section sets out the end-to-end Code objectives for network performance. Two approaches to the specification of compliance objectives are employed as follows:

- (a) objectives for end-to-end operational measurement of network performance.

- (b) objectives for the network design performance of end-to-end connections which may be provided by the interconnection of a number of individual networks.
- 6.2.2 Objectives for end-to-end measurement of network performance are specified for parameters for which it is practical to perform operational end-to-end measurement (i.e. connectivity parameters). Section 8.1 (Routine End-to-End Operational Measurement) and Section 8.3 (Operational Measurement by Exception) detail the methods to be applied for operational end-to-end measurement of network performance parameters. Compliance with the operational end-to-end measurement objectives demonstrates industry compliance with this Code.
- 6.2.3 Network design objectives for end-to-end connections are specified for the transmission parameters. Section 8.2 (Routine Compliance by Self-Attestation) and Section 8.4 (Independent Network Design Verification) detail the compliance methods for verification of design parameters so that individual network contributions to end-to-end network performance can be verified.
- 6.2.4 Compliance with network design parameters indicates an individual Code Participant's compliance with this Code and assists the industry to achieve effective interworking. The ANPP provides a more detailed description of these network performance parameters.

End-to-End Connection Setup Failure

- 6.2.5 Table 6.2 specifies the minimum network performance levels for end-to-end Connection Setup Failure. Calls made to non-geographic service number FNTs are not included in these network performance levels.

Connection Service Type	Average Monthly Value
FNT-FNT (Local)	3%
FNT-FNT (Long Distance)	5%
FNT-MAI	8%
MAI-FNT	8%
MAI-MAI	10%

TABLE 6.2
Minimum network performance levels for end-to-end Connection Setup Failure

- 6.2.6 Industry compliance with the network performance levels specified in Table 6.2 shall be shown routinely by Compliance Test Method 1 of Section 8.1. If compliance verification by exception testing is required, Compliance Test Method 3 (Operational Measurement by Exception) of Section 8.3 shall be applied.

Post Dialling Delay

- 6.2.7 Table 6.3 specifies the minimum network performance levels for Post Dialling Delay. Calls made to non-geographic service number FNTs are not included in these network performance levels.

Connection Service Type	Mean Value (Seconds)	90th Percentile Value (Seconds)
FNT-FNT (Local)	6	15
FNT-FNT (Long Distance)	9	20
FNT-MAI	15	<i>ffs</i>
MAI-FNT	10	<i>ffs</i>
MAI-MAI	19	<i>ffs</i>

ffs: for further study. To be specified by ACIF following analysis of operational measurements involving mobile networks.

TABLE 6.3

Minimum network performance levels for Post Dialling Delay.

- 6.2.8 Industry compliance with the network performance levels specified in Table 6.3 shall be shown routinely by Compliance Test Method 1 of Section 8.1. If compliance verification by exception testing is required, Compliance Test Method 3 (Operational Measurement by Exception) of Section 8.3 shall be applied.

Transmission Loss and Nominal Relative Network Levels

- 6.2.9 Maximum end-to-end Transmission Loss is not to be more than 28 dB at 1020 Hz using nominal design values for all network components e.g. cables, PCM codecs.
- 6.2.10 Transmission Loss (also known as composite loss) as defined in Section 5.2 is a voltage loss from the generator to the load with respect to the actual source and terminating impedances being used in service. These impedances can in general be complex.
- 6.2.11 Nominal relative network levels in a fixed network reference connection are given in Figure 6.2 (reproduced from ANPP Figure 7.1.1).

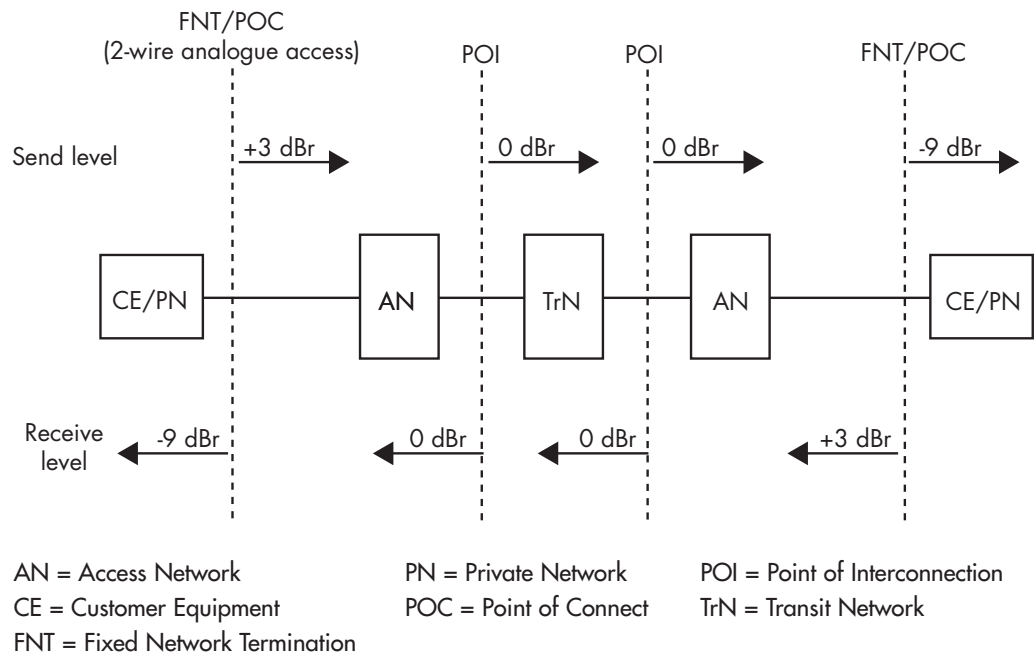

FIGURE 6.2
Nominal relative levels in a fixed network reference connection

6.2.12 Industry compliance with the network performance levels for Transmission Loss and nominal relative network levels specified above shall be shown by Compliance Test Method 2 (Routine Compliance by Self-Attestation) of Section 8.2. If compliance verification by exception testing is required, Compliance Test Method 4 (Independent Network Design Verification) of Section 8.4 shall be applied.

Loudness Loss

6.2.13 The maximum Overall Loudness Rating (OLR) allowable is 29.5 dB. This assumes the following:

- (a) Customer Equipment (CE) send and receive loudness sensitivities shall conform to at least TS 004.
- (b) use of nominal design values for CE send and receive loudness ratings (excluding manufacturing tolerance).
- (c) use of nominal design loudness ratings of network components, e.g. cables, PCM codecs.
- (d) weighting factors to calculate loudness ratings are in accordance to Table 1 of ITU-T Recommendation P.79 when the frequency band 200 Hz - 4000 Hz is used, or in accordance with Table A.2 of ITU-T Recommendation P.79 when the frequency band 100 Hz - 8000 Hz is used.
- (e) transmission loss as defined in Section 5.2 shall be used in the calculation of loudness ratings.

- 6.2.14 Industry compliance with the maximum Overall Loudness Rating of 29.5 dB shall be shown by Compliance Test Method 2 (Routine Compliance by Self-Attestation) of Section 8.2. If compliance verification by exception testing is required, Compliance Test Method 4 (Independent Network Design Verification) of Section 8.4 shall be applied.

Circuit Noise

- 6.2.15 End-to-end design limit for circuit noise shall not be more than -41 dBm0p. The received relative level at the FNT/POC is assumed to be a -9 dB point.
- 6.2.16 Industry compliance with the end-to-end design limit for circuit noise of not more than -41 dBm0p shall be shown by Compliance Test Method 2 (Routine Compliance by Self-Attestation) of Section 8.2. If compliance verification by exception testing is required, Compliance Test Method 4 (Independent Network Design Verification) of Section 8.4 shall be applied.

Delay and Echo

Delay

- 6.2.17 The maximum allowable delays are given in Table 6.4. The delays through Public Digital Mobile Networks are derived from ETSI GSM performance specifications. However, non-GSM Public Digital Mobile Networks are expected to meet these delay values.

Network Portion	Round Trip Delay (non-satellite connections)	Mean One-way Propagation Time (non-satellite connections)	Mean One-way Propagation Time (including one GEO satellite hop) (Note 3)
FNT-FNT	150 + 150 ms	150 ms	410 ms
FNT-MAI (note 1)	150 + 150 ms	150 ms	410 ms
FNT-MAI (notes 1,2)	150 + 150 ms	150 ms	410 ms
FNT-POI	150 ms	75 ms	335 ms
FNT-POC	150 ms	75 ms	335 ms

Note 1: Delay contribution by mobile handset is not included.

Note 2: Fixed network portion delay is not included.

Note 3: One GEO satellite hop contributes 260 ms delay.

TABLE 6.4
Requirements for delay

Echo Control

- 6.2.18 Echo cancellers shall be employed when the round trip delay exceeds 34 ms. This requirement does not apply to global calls and to calls which are to be diverted. Application to these calls is for further study.
- 6.2.19 Public Digital Mobile Network access Service Deliverers will provide echo cancellers within their networks for both call directions.

6.2.20 Industry compliance with the network performance levels for delay specified in Table 6.4 and for the provision of echo cancellers when the round trip delay exceeds 34 ms shall be shown by Compliance Test Method 2 (Routine Compliance by Self-Attestation) of Section 8.2. If compliance verification by exception testing is required, Compliance Test Method 4 (Independent Network Design Verification) of Section 8.4 shall be applied.

Network Synchronisation and Slip

6.2.21 Ideally, there is no slip in a synchronised network where all timing is derived from a primary reference clock (PRC) source. Most transit and local clocks obtain synchronisation via dual links from the PRC. When both links distributing the clock signal are lost, the transit and local clocks enter hold-over mode. However based on ITU-T Clock Recommendations, it takes some time for a slip to occur. By this time, the link would have been fixed and the clocks would be synchronised again. Slips can occur in customer equipment, however this is not a network performance issue.

6.2.22 In a multi-network environment where each network may have its own PRC source, the networks would only operate plesiochronously with one another and therefore slips can occur.

6.2.23 A CE must act as a slave to the public network (Reference:TS 016).A private network must be synchronised from a reference source traceable to a PRC (Reference:TS 012). A private network can have its own PRC or accept PRC-traceable timing from the public network.

6.2.24 The slip performance of a 64 kbit/s connection shall conform to Table 1 of ITU-T G.822, reproduced as Table 6.5 in this Code.

Performance Category	Mean Slip Rate	Proportion of time (Note 1)
(a) (Note 2)	≤ 5 slips in 24 hours	> 98.9%
(b)	> 5 slips in 24 hours ≤ 30 slips in 1 hour	< 1.0%
(c)	> 30 slips in 1 hour	<0.1%

Note 1 - Total time ≥ 1 year.

Note 2 - The nominal slip performance due to plesiochronous operation alone is not expected to exceed 1 slip in 5.8 days.

TABLE 6.5
Controlled slip performance on a 64 kbit/s connection (reproduced from ITU-T Table 1/G.822)

6.2.25 Industry compliance with the performance levels specified in Table 6.5 shall be shown by Compliance Test Method 2 (Routine Compliance by Self-Attestation) of Section 8.2. If compliance verification by exception testing is required, Compliance Test Method 4 (Independent Network Design Verification) of Section 8.4 shall be applied.

INDUSTRY CODE

7 COMPLIANCE PROCESS

The operation of the Code and the administration of compliance with the objectives of the Code will follow the process shown in Figure 7.1. Compliance with the requirements of the Code shall be demonstrated by Code Participants. The overall process has three main areas of activity as follows:

- (a) Routine Compliance Verification
 - (i) operational measurement (for connectivity parameters)
 - (ii) self-attestation of compliance with the Code (for transmission parameters).
- (b) identification of Performance Anomalies
 - (i) identification and attempted resolution of Industry complaints
 - (ii) identification of a trend or pattern of consumer network performance complaint issues obtained from other agencies or industry performance reports.
- (c) Compliance Verification by Exception Testing
 - (i) directed operational measurement (for connectivity parameters)
 - (ii) independent verification of network design (for transmission parameters)
 - (iii) ACIF investigation and problem solving.

Three outcomes are possible as a result of the Code administration process:

- (a) end-to-end network performance is perceived by consumers and the industry as satisfactory
- (b) enforcement actions or sanctions as detailed in Section 10 are applied to breaches of the Code
- (c) ACIF reviews the Code to address identified deficiencies.

7.1 Routine Compliance Verification

- 7.1.1 The routine verification of compliance to the end-to-end network performance Code will address compliance associated with both the operational measurement (for connectivity parameters) and assessments of individual network performance contributions (for transmission parameters).
- 7.1.2 ACIF enforcement actions (which may include sanctions determined by an Independent Complaints Investigator) may be applied should ACIF requests for compliance with routine verification tests not be acted upon.

Operational Measurement

- 7.1.3 Code Participants shall demonstrate compliance to the end-to-end network performance objectives for Connection Setup Failure and Post Dialling Delay by Compliance Test Method 1 described in Section 8.1. ACIF in consultation with industry, taking into consideration resources and capabilities within Code Participants' networks, will administer these measurements. To the extent that they are lawfully entitled to, Code Participants will be required to provide ACIF with details of customers, access switch technology if relevant, geographic coverage, traffic flows and any other details required to determine a representative measurement approach as detailed in Clauses 8.1.3 and 8.1.4. ACIF must ensure confidentiality of this information, in accordance with Section 9.5 of this Code.

Attestation of Performance

- 7.1.4 Code Participants shall demonstrate compliance against the end-to-end network performance objectives for the transmission parameters using the attestation of performance approach described in Section 8.2 (Compliance Test Method 2).

ACIF Diagnosis and Rectification

- 7.1.5 Should any section of the industry fail to comply with the requirements of the routine compliance tests, ACIF may elect to involve itself directly in the problem resolution process. ACIF may review a Code Participant's "network design document" and/or recommend specific network tests to be performed. This process could involve ACIF using independent industry experts. Measurements derived from this process will be used only as an aid to the resolution of the problem and not form part of the compliance objectives.
- 7.1.6 To demonstrate that the problem has been rectified, compliance with the requirements of the routine compliance tests (i.e. Compliance Test Method 1 and Compliance Test Method 2) will need to be demonstrated.

7.2 Identification of Performance Anomalies

- 7.2.1 The Code Participants will regularly, as set out in Clause 8.1.8 and Section 8.2, demonstrate compliance with the requirements of the routine verification tests. Even with this demonstrated compliance there may be occasions where there are:
- (a) complaints on network performance from industry participants
 - (b) a trend or pattern of consumer complaints relating to network performance obtained from other agencies or industry performance reports.

Industry Network Performance Complaints

- 7.2.2 ACIF, upon determining there is a networking problem or network performance issue requiring attention, will normally request that service deliverers, either individually or collectively with others, meet to diagnose and resolve this issue, using whatever measures the service deliverers deem appropriate, e.g. design reviews or network tests or monitoring of live traffic. ACIF will normally also advise a timeframe for reporting back the findings. ACIF will not directly involve itself in the resolution of the problems but will facilitate the industry to resolve the issues directly.
- 7.2.3 If the issues cannot be resolved by the Code Participants, ACIF may direct that the compliance verification by exception testing process be applied.

Trend or Pattern of Consumer Network Performance Complaint

- 7.2.4 In response to a trend or pattern of consumer complaints from other agencies or industry performance reports ACIF will work with the industry or Independent Complaints Investigators to determine if there is a network performance issue and if so resolve the issue.
- 7.2.5 If the issues cannot be resolved ACIF may direct that the compliance verification by exception testing process be applied.

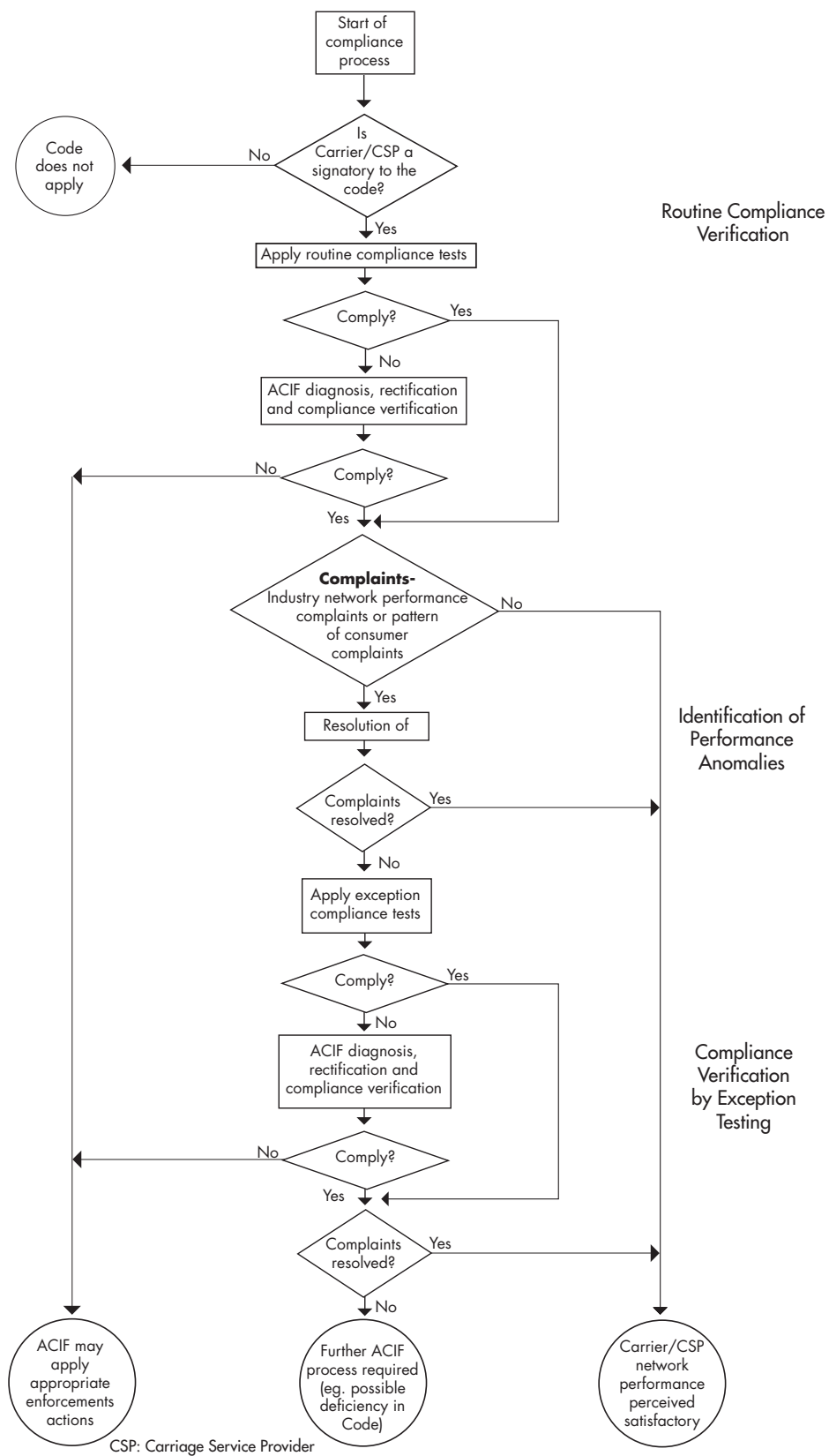

FIGURE 7.1
Flow Chart of Compliance Process for Code

7.3 Compliance Verification by Exception Testing

- 7.3.1 ACIF may, in response to the industry's inability to resolve network performance complaints, direct that compliance verification by exception testing be applied.
- 7.3.2 On-going failure by a Code Participant to pass the requirements of the compliance verification by exception testings may result in ACIF enforcement action (which may include sanctions determined by an Independent Complaints Investigator).

Directed Operational Measurement

- 7.3.3 For the operational measurements associated with compliance verification by exception, ACIF may call for operational measurement of end-to-end connectivity performance directed at a specified regional area or involving the networks of particular Code Participants. The measurement approach is described as Compliance Test Method 3 in Section 8.3.
- 7.3.4 ACIF will administer, to the extent that they are lawfully able to do so, these measurements. Code Participants will be required to provide ACIF with details of customers, access switch technology if relevant, geographic coverage, traffic flows and assist in developing a representative measurement approach. ACIF must ensure confidentiality of this information, in accordance with Section 9.5 of this Code.

Independent Network Design Verification

- 7.3.5 For compliance testing by exception ACIF will require Code Participants to show compliance against the end-to-end objectives for the transmission parameters by applying independent verification of network design objectives. The compliance approach is described as Compliance Test Method 4 in Section 8.4.

ACIF Diagnosis and Rectification

- 7.3.6 Should any section of the industry fail to comply with the requirements of the compliance verification by exception tests, ACIF may elect to involve itself directly in the problem resolution process. ACIF may review a Code Participant's "network design document" and/or recommend specific network tests to be performed. This process could involve ACIF using independent industry experts. Measurements derived from this process will be used only as an aid to the resolution of the problem and not form part of the compliance objectives.
- 7.3.7 To demonstrate that the problem has been rectified, compliance with the requirements of the compliance verification by exception testing (i.e. Compliance Test Method 3 and Compliance Test method 4) will need to be demonstrated.

8 COMPLIANCE TEST METHODS

This section describes the test methods that are required for compliance in line with the relevant administration considerations of Section 7. ACIF will administer these Compliance Test Methods.

8.1 Compliance Test Method 1 - Routine End-to-End Operational Measurement

8.1.1 Compliance with the objectives for end-to-end network performance across networks shall be determined by the use of artificially generated test calls.

8.1.2 Collection of data shall be in accordance with Clauses 8.1.3 to 8.1.7.

Distribution of Measurement Devices

8.1.3 Test Call transponders shall be distributed across access networks in Australia so as to provide a generally representative view of:

- (a) access networks of Carriers and CSPs offering service to consumers in Australia.
- (b) geographic dispersion of consumers.
- (c) technology used in providing access network infrastructure.

Distribution of Test Calls

8.1.4 A schedule of test calls shall be developed by ensuring that the test call distribution is generally representative of traffic flows in the network with respect to:

- (a) distribution of traffic with time of day.
- (b) distribution of traffic between origins and destinations.
- (c) distribution of traffic between and among Carriers and CSPs.

Measurement Periods

8.1.5 The conditions affecting the timing and extent of measurements are:

- (a) measurements shall cover 24 hour periods.
- (b) the measurement period shall be one month per reporting period specified in Clause 8.1.8.

Number of Test Calls Required

8.1.6 Sufficient calls will be made to ensure that a precision of at least (10% of the value of the objective for Connection Setup Failure can be determined with a 95% degree of confidence. The same calls that are used to determine Connection Setup Failure for each service interconnection class (e.g. FNT-FNT, FNT-MAI, etc.) will be used to determine the corresponding Post Dialling Delay parameters.

Criteria for Achievement of Objectives

8.1.7 The objective will be deemed to have been achieved as follows:

- (a) for measurements of the mean value - if the upper limit of the 95% confidence interval is less than or equal to the objective.
- (b) for measurements of the percentile of delay parameters - if the percentile value (as determined from the total call sample for the service interconnection class) is less than or equal to the objective.

Reporting Period

- 8.1.8 The reporting period shall be half-year or other period as reasonably determined by ACIF. The report shall be published within 3 months after the end of the reporting period.

8.2 Compliance Test Method 2 - Routine Compliance by Self-Attestation

- 8.2.1 For the network performance parameters specified in this Code, the Code Participant shall provide a self-attestation each year that states the design of its network meets the end-to-end requirements of this Code.
- 8.2.2 For this self-attestation, the Code Participant shall establish and maintain a “network design document”, which is suitable for allowing an independent party to verify network compliance. If this “network design document” references any other information, the referenced material also should be accessible if independent verification is required under Compliance Test Method 4.
- 8.2.3 It is envisaged that such documentation will contain at least the following components:
- (a) the different call case scenarios provided by the Code Participant, e.g. showing access network and/or transit network operation,
 - (b) network plans,
 - (c) other Carriers used and their network apportionment (if necessary),
 - (d) equipment specifications,
 - (e) network design specifications.

8.3 Compliance Test Method 3 - Operational Measurement by Exception

- 8.3.1 ACIF or its duly authorised agent may request testing of end-to-end connectivity performance directed at a specified regional area or involving the networks of particular Code Participants. These tests will be applied to demonstrate compliance in situations where network performance anomalies have been reported and remedial action taken. To demonstrate compliance, ACIF or its duly authorised agent will direct end-to-end network performance tests localised to the regions associated with reported network performance anomalies. Measurements will be as detailed in Clauses 8.1.3 to 8.1.7 and the report is to be published as soon as practical after the measurements have been performed. Network performance objectives will be the same as for Compliance Test Method 1.

8.4 Compliance Test Method 4 - Independent Network Design Verification

- 8.4.1 Upon ACIF’s request, the Code Participant shall provide ACIF or its duly authorised agent the network design documentation referenced in Section 8.2. ACIF or its duly authorised agent will then verify that the documentation substantiates the self-attestation.
- 8.4.2 The process for Code administration will be in accordance with ACIF’s Code Administration and Compliance Scheme.
- 8.4.3 The Code will be administered by the ACIF Executive.

9 CODE ADMINISTRATION

9.1 Registering Participation

- 9.1.1 Parties wishing to become a Code Participant will be required to become signatories to the Code by completing the ACIF Code Participation Form. This action will register their participation and intended compliance with the Code.
- 9.1.2 A participant register will be maintained by the ACIF Executive and will be publicised on the ACIF web site.
- 9.1.3 ACIF will publish a list of Code Participants and their status in relation to the Code.
- 9.1.4 There are three status categories:
- (a) compliant
 - (i) the Code Participant is compliant to Compliance Test Method 2.
 - (ii) the Code Participant is co-operating with ACIF in relation to any matters raised for Compliance Test Methods 1, 3 and 4.
 - (b) co-operating
 - (i) preparation or conduct of Compliance Test Method 1 is underway and the Code Participant is awaiting a report of industry compliance.
 - (ii) Compliance Test Method 2 is underway and the Code Participant is awaiting a report of compliance.
 - (c) non-compliant
 - (i) a Code Participant will be listed as non-compliant if the ACIF Executive has determined a breach of the Code as per Section 10 below has occurred and the Code Participant has had a public censure notice imposed as a sanction.
 - (ii) any Direction by the ACA under section 121 of the Telecommunications Act, 1997 to a Code Participant will be noted in the report.

9.2 Publicity

- 9.2.1 At the commencement of the Code and periodically, the ACIF Executive will publicise the following:
- (a) Code objectives
 - (b) Code participation
 - (c) existence of the ACIF Code regime
 - (d) complaint handling procedures
- 9.2.2 The ACIF web site, newsletter and metropolitan and regional media will be used as the main publicity vehicles.
- 9.2.3 Code Participants will be required to inform and educate their employees of the following:
- (a) the Code and its implications to employees
 - (b) their participation in the ACIF Code regime

Publicity of Compliance Test Method 1 Outcome

- 9.2.4 ACIF will publish a set of consolidated industry results as set out in Clause 8.1.8 and in accordance with the Scheme.

Publicity of Compliance Test Method 2 Outcome

- 9.2.5 ACIF will publish a list of those Code Participants who provide a self-attestation that their networks meet the requirements of this Code.

Publicity of Compliance Test Method 3 Outcome

- 9.2.6 ACIF shall keep a confidential register of the Code Participants who have been requested to perform Compliance Test Method 3 and the Code Participants who have been requested to take corrective action.

- 9.2.7 ACIF will publish the list of Code Participants who have been found to be in breach of the Code and have had a public censure notice imposed as a sanction.

Publicity of Compliance Test Method 4 Outcome

- 9.2.8 ACIF shall keep a confidential register of the Code Participants who have been requested to have their network design independently verified.

- 9.2.9 ACIF will publish the list of Code Participants who have been found to be in breach of the Code and have had a public censure notice imposed as a sanction.

9.3 Financial and Sanction Administration

- 9.3.1 ACIF will coordinate the financial administration of the Code system and administration of sanctions.

9.4 ACIF Administration of Compliance Testing

- 9.4.1 ACIF or its duly authorised agent shall direct compliance testing as follows:

(a) test call system facilities

For Compliance Test Methods 1 and 3 ACIF or its duly authorised agent shall co-ordinate the use of test call system facilities. With the agreement of ACIF or its duly authorised agent, such agreement not to be unreasonably withheld, Code Participants may be able to make use of existing test call systems or contract third parties to measure their own networks and to originate and or terminate calls to and from other Carrier or CSP networks. If additional test call system facilities are needed for complete network testing, the use of such facilities shall be arranged by ACIF or its duly authorised agent, in consultation with the relevant Code Participants.

(b) allocation of transponders and call distributions

ACIF or its duly authorised agent shall set up a committee of Code Participant representatives to develop the schedules of transponder locations and call distributions and for inter-carrier/CSP testing. The development of the schedules will be based on actual network traffic flow and call distributions information provided by Code Participants. Where possible use shall be made of transponders controlled by Code Participants in their existing locations. The measurement approach, including schedules of transponder locations and call distributions for end-to-end testing wholly within a Code Participants network may be developed by that Code Participant. ACIF or its duly authorised agent shall review the measurement approach developed by the committee of Code Participant representatives for inter-carrier/CSP testing and review the measurement approaches developed by Code Participants for

intra-carrier/CSP testing to ensure compliance with the requirements of Compliance Test Methods 1 and 3.

confidentiality of each individual Code Participant's network and traffic flow information shall be maintained, in accordance with Section 9.5 of this Code.

(c) conducting test call measurements, analysis and reporting of results

ACIF or its duly authorised agent in consultation with Code Participants shall determine the commencement date of the measurement period for Code Participants or ACIF's contracted agents to conduct test call measurements. At least 3 months notice of the commencement date of the measurement period will be provided to allow the measurement facilities to be prepared. ACIF or its duly authorised agent shall assemble results for the overall network and report to ACIF. Confidentiality of each individual Code Participant's network performance information shall be maintained, in accordance with Section 9.5 of this Code.

(d) design documentation verification

ACIF or its duly authorised agent shall verify Code Participants' network design documentation in accordance with the requirements of Compliance Test Method 4.

(e) funding of compliance testing process

- (i) Code Participants shall contribute to the costs of compliance testing as reasonably determined by ACIF or its duly authorised agent in consultation with participating Code Participants. The costs will include the costs of obtaining the use of measurement equipment, performing tests and any other costs associated with compliance testing, analysis and reporting. Costs relating to routine compliance verification, other than a Code Participant's costs relating to self-attestation, shall be apportioned equitably, based on the relative proportion of telephone traffic carried by each Code Participant's network. In allocating costs, reasonable allowance shall be made to offset the costs of measurements provided by Code Participant's use of their own test call system facilities or measurements performed on their behalf by contracted third parties.
- (ii) A Code Participant's costs relating to self-attestation shall be paid by that Code Participant.
- (iii) Costs relating to compliance verification by exception testing shall be apportioned to the Code Participant(s) whose network performance anomalies resulted in that testing.

9.5 Confidentiality

9.5.1 ACIF shall protect and preserve the confidential nature of the Confidential Information and, in particular, prevent third parties from gaining access to the Confidential Information.

9.5.2 ACIF shall not:

- (a) use any Confidential Information other than for purposes directly associated with this Code;
- (b) disclose to any other person (other than ACIF's duly authorised agent) all or any of the Confidential Information;

without a Code Participant's prior written consent.

- 9.5.3 ACIF shall:
- (a) use Confidential Information only for purposes which are in accordance with this Code;
 - (b) ensure that Confidential Information is secured, stored and accessible only by employees or its duly authorised agent;
 - (c) ensure that its employees or its duly authorised agent shall not make any unauthorised use or disclosure of Confidential Information and shall comply with the requirements as to confidentiality set out in this Section of the Code as if they were ACIF;
 - (d) immediately notify a Code Participant if it becomes aware of any unauthorised use or disclosure or threatened use or disclosure of the Confidential Information.
- 9.5.4 ACIF may disclose Confidential Information as required by law.

9.6 Code Review

- 9.6.1 In association with ACIF's Network Reference Panel, the ACIF Executive will be responsible for the review of the Code. The review will be in accordance with the Scheme.

9.7 Code Amendment

- 9.7.1 In association with ACIF's Network Reference Panel, the ACIF Executive will be responsible for the amendments to the Code. The amendments will be in accordance with ACIF's Code Administration and Compliance Scheme.

10 CODE COMPLAINT MANAGEMENT PROCESS AND SANCTIONS

- 10.1 ACIF will administer and co-ordinate compliance with this Code.
- 10.2 Table 10.1 provides a description of types of conduct which constitute breaches of this Code and which would lead to the Implementation of the Code Complaint Management Process.
- 10.3 Confidentiality issues relating to ACIF action and the sanctions applicable for breach of the Code are provided in the ACIF Code Administration and Compliance Scheme.

Method	Conduct
Compliance Test Method 1	<ul style="list-style-type: none"> • A Code Participant fails to meet ACIF target dates for supply of test results and other information relevant to the Code • A Code Participant claims to meet the Code but refuses to participate in an ACIF prescribed test program • The industry fails to meet network performance targets for three consecutive reporting periods and a Code Participant does not provide evidence of corrective action being taken as requested by ACIF
Compliance Test Method 2	<ul style="list-style-type: none"> • A Code Participant fails to meet ACIF target dates for providing self-attestation • A Code Participant fails to provide annual self-attestation
Compliance Test Method 3	<ul style="list-style-type: none"> • A Code Participant fails to meet ACIF target dates for supplying test results or completing corrective action • A Code Participant fails to participate or cooperate in an ACIF prescribed test program • A Code Participant consistently fails to address proven poor network performance significantly affecting customers or other Carriers or CSPs • A Code Participant fails to take corrective action when investigation reveals a networking problem
Compliance Test Method 4	<ul style="list-style-type: none"> • A Code Participant fails to provide network design verification information when requested • A Code Participant fails to address non-compliance of its network design • A Code Participant fails to take corrective action to address deficiencies in network design verification information

TABLE 10.1

Types of conduct which constitute breaches of the Code

A Code Participant will be listed as non-compliant if ACIF has determined a breach of the Code (above) has occurred and the Code Participant has had a public censure notice imposed as a sanction.

AUSTRALIAN COMMUNICATIONS INDUSTRY FORUM LTD (ACIF)

The Australian Communications Industry Forum Ltd (ACIF) is a communications self-regulatory body established in 1997 by the industry to manage communications self-regulation within Australia.

The primary role of ACIF is to develop and administer Technical Standards, Industry Codes and industry support services that promote both the long-term interest of end-users and the efficiency and international competitiveness of the Australian communications industry.

ACIF is an industry initiative, funded and resourced by the industry, with a membership that encompasses all industry sectors. ACIF comprises a Board, Advisory Assembly, Executive, six standing Reference Panels and a number of task-specific Working Committees.

Technical Standards and Industry Codes are prepared by Working Committees made up of experts from industry, consumer, government, and other bodies. The requirements or recommendations contained in ACIF's published documents are a consensus of views of representative interests and also take into account comments received from other sources.

Care should be taken to ensure that material used is from the current version of the Standard or Code and that it is updated whenever the Standard or Code is amended or revised. The number and date of the Standard or Code should therefore be clearly identified. If in doubt please contact ACIF.



Published by:

**THE AUSTRALIAN COMMUNICATIONS
INDUSTRY FORUM LTD**

Level 9, 32 Walker Street
North Sydney NSW 2060

Correspondence: PO Box 444
Milsons Point NSW 1565

Telephone: (02) 9959 9111

Facsimile: (02) 9954 6136

E-mail: acif@acif.org.au

Web Site: <http://www.acif.org.au/>